

DATASHEET

# DIAMOND WIRE SAW

SUBSEA INTERVENTION  
CUTTING & GRINDING  
112399

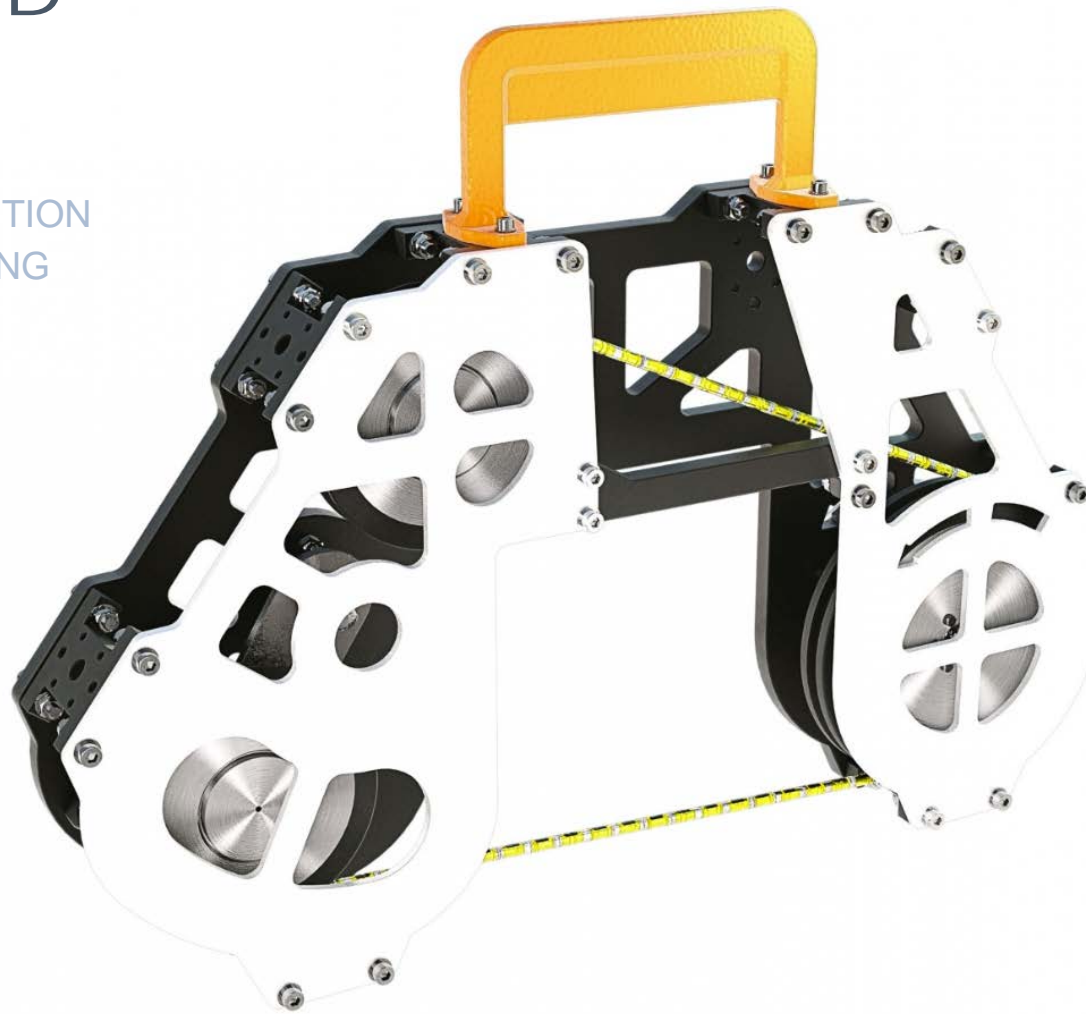

**Subsea Diamond Wire Saw with a range up to 320mm.**

**The DWS is designed for use by ROV and for various cutting operations where conventional rotating blades are insufficient.**

The saw is designed to cut steel pipes, steel profiles and wires.

Available for sale and rental

## FEATURES

- Compact
- Low weight
- Field proven
- Available for both sales and rental

# Specifications

## General Technical Data

Product No.	112399	
Model	DWS 320mm - 7644-005	
Weight in air / submerged	KG	42 / 26.9
Dimensions (mm)	(W x H x L)	716 x 157.5 (293) x 954

## Hydraulic Technical Data

Pump Displacement	cm <sup>3</sup> /rev.	46	
Max. supply pressure	Bar (PSI)	103	(1500)
Max. working pressure	Bar (PSI)	97	(1400)
Max. supply flow	LPM (GPM)	45	(11.8)

## Interfaces

Motor Supply Port	JIC 8 (3/4-16") – Male
Motor Return Port	JIC 8 (3/4-16") – Male
Feed Supply	JIC 8 (3/4-16") – Male
Feed Return	JIC 8 (3/4-16") – Male
Clamp ON	JIC 8 (3/4-16") – Male
Clamp OFF	JIC 8 (3/4-16") – Male

